

Van Stone Thermowells

FEATURES

- One piece bar stock construction
- Stamped with mill traceable material and heat number
- Testing and certifications including Wake Frequency Calculations per ASME PTC 19.3 TW-2016
- Standard or customized shank dimensions

TYPICAL USES

- Chemical and Petrochemical Plants
- Water and Wastewater Temperature Control



Van Stone Thermowells
1", 1½" Van Stone sizes

SPECIFICATIONS

Shank Style:	Tapered
Process Connection:	1", 1½"
Instrument Connection:	½ NPSM, ½ NPT Female
Bore Size:	0.260", 0.385"
Flange Rating:	Lap Joint Backing
Rating/Class:	150, 300, 600
Surface Finish:	16-32 RA
Lagging:	2": if U-dimension is <3" 3": if U-dimension is >3"
Cap and Chain:	Brass, SS

KEY BENEFITS

- Protects instrument against corrosive effects and physical damage caused by media flow
- Permits instrument interchange or calibration check without disturbing/closing down the process
- Tracing of material origin for quality assurance and control

TABLE 1

OPTIONS	CODE
Stamp tag number on thermowell	NF
SS tag wired to thermowell	NH
Hydrostatic test-internal	W9
Clean for oxygen service	6B
Wake frequency calculation	W5
Material origin restriction	UM

Certificates

Certificate of Conformance (per order)	CD-1A
Physical and Chemical Material Test Report (MTR's)	W6
Positive Material Identification (PMI) N/A Carbon Steel	MQ
NACE Certificate of Compliance	CD-5

TABLE 2

MATERIALS	CODE
304 SS	C
316 SS	S
Monel®	M
Hastelloy B/C	G/H
Carpenter 20	D
Chrome Moly F11/F22	FA/FB
Duplex 2205 S/S	J
Super Duplex S32750	SD
Iconel 600	W
Titanium	TI
Carbon Steel	B

Data Sheet

Van Stone Thermowells

ORDERING CODE	Example:	10	W	0400	L	H	V	260	S	2	XNF	F	150	L0350
Process Connection Size														
10 - 1"		10												
15 - 1½"														
Thermowell														
W - Thermowell			W											
U-Process Insertion Length														
0400 - 4"				0400										
0700 - 7"														
1000 - 10"														
1300 - 13"														
1600 - 16"														
2200 - 22"														
Instrument Connection														
Blank - ½ NPSM														
2 - ½ NPT Female														
Lagging														
Blank - No lagging														
L - Lagging (For special lag length, see below)					L									
Shank														
H - Tapered						H								
Process Connection														
V - Van Stone							V							
D-Bore Diameter														
260 - 0.260"								260						
385 - 0.385"														
Material (Refer to Table 2)														
C - 304 SS														
S - 316 SS									S					
Cap and Chain														
Blank - No cap and chain														
1 - Brass														
2 - SS										2				
Options - (see Table 1 on page 1 for additional options (If choosing an option(s) must include an "X")											X			
NF - Stamp tag number on thermowell												NF		
Flange Facing														
F - Flat													F	
R - Raised														
J - Ring joint														
L - Lap joint														
Flange Rating														
150 - 150														150
300 - 300														
600 - 600														
Special Lagging Length														
L - Lagging length × 100 (ex: 3.5" × 100 = L0350)														L0350

Van Stone Thermowells

DIMENSIONS

For reference only, consult Ashcroft for specific dimensional drawings

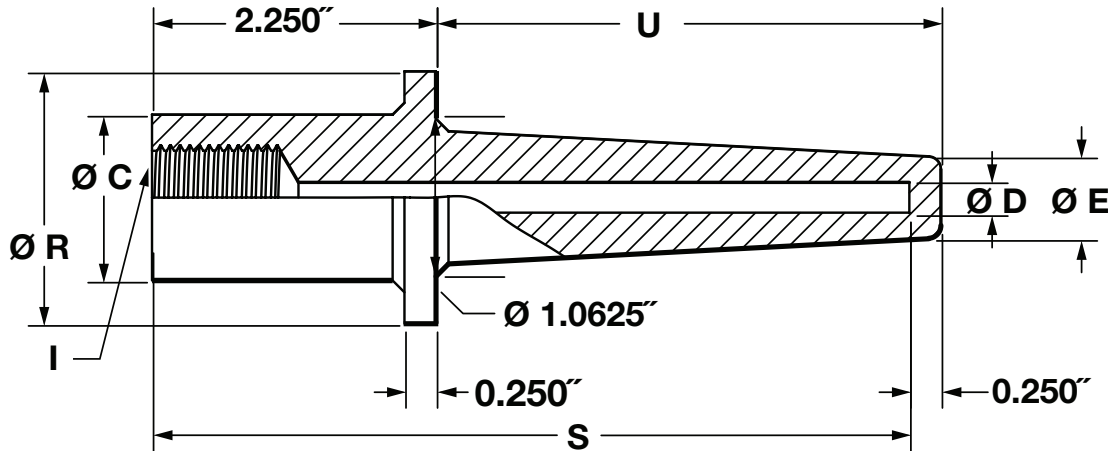

DIMENSION (Inches)			PART NUMBER	
P	S	U	¼" Bore	⅜" Bore
1	4	2	10W0200HV260	10W0200HV385
1½			15W0200HV260	15W0200HV385
1	6	4	10W0400HV260	10W0400HV385
1½			15W0400HV260	15W0400HV385
1	9	7	10W0700HV260	10W0700HV385
1½			15W0700HV260	15W0700HV385
1	12	10	10W1000HV260	10W1000HV385
1½			15W1000HV260	15W1000HV385
1	15	13	10W1300HV260	10W1300HV385
1½			15W1300HV260	15W1300HV385
1	18	16	10W1600HV260	10W1600HV385
1½			15W1600HV260	15W1600HV385
1	24	22	10W2200HV260	10W2200HV385
1½			15W2200HV260	15W2200HV385

Van Stone Tapered - 0.260 & 0.385 Bore		
P	C	R
1"	1.315"	2.00"
1½"	1.90"	2.875"

Thermowell Legend

I - Instrument connection (½" NPSM is STD.)

E - Tip O.D.

D - Bore diameter

U - Insertion depth

S - Instrument stem length or bore depth

C - Hub diameter

R - Raised face diameter