

## 510/511 All Welded Diaphragm Seal

### FEATURES

- Compact design allows seals to fit in confined areas
- Sufficient displacement to drive a wide variety of instrumentation
- Minimal fill volume
- All stainless steel construction; other materials available
- Light weight design

### TYPICAL USES

- Oil and gas
- Refineries (Hydrofluoric / Sulfuric Alkylation)
- Chemical and petrochemical
- Water and wastewater
- Oil and gas fracking
- NACE Compliant processes (sour gas separation)
- Biogas and biodiesel
- Corrosive processes



**510/511**  
Threaded Seals



### SPECIFICATIONS

Connection Style: 510: Threaded  
511: Threaded with Flushed Connection

Process Connection Size: ½ NPT Male

Instrument Connection Size: ½ NPT Female

Pressure Rating (MAWP): Vac. to 1,500 psi at 100°F  
(high pressure option available)

Added Tolerance: ±0.5% typical

Fill Fluid: Glycerin, Silicone, Halocarbon<sup>®</sup>, Syltherm<sup>®</sup>

Approvals: CRN, NACE

### WETTED COMPONENTS

Diaphragm	Lower Housing
316L SS	316L SS
Hastelloy <sup>®</sup> C-276	Hastelloy <sup>®</sup> C-276
Monel <sup>®</sup> 400	Monel <sup>®</sup> 400
Duplex 2205	Duplex 2205

### NON-WETTED COMPONENTS

Top Housing
316 SS, Hastelloy <sup>®</sup> C-276, Monel <sup>®</sup> 400, Duplex 2205

### KEY BENEFITS

- Continuous duty design
- All-welded construction prevents inadvertent disassembly
- Ensures process compatibility
- Male connections eliminate adapters/fittings

# Data Sheet

## 510/511 All Welded Diaphragm Seal

ORDERING CODE	Example:	04	510	S	S	04T	XCG	NH
<b>Process Connection Size</b>								
04 - ½ NPT Male		04						
<b>Seal Model</b>								
510 - All-welded threaded compact seal, with no flushing port			510					
511 - All-welded threaded compact seal, with flushing port								
<b>Diaphragm Material</b>								
S - 316L Stainless Steel				S				
H - Hastelloy <sup>®</sup> C-276								
P - Monel <sup>®</sup> 400								
Z - Duplex 2205								
<b>Bottom Housing Material</b>								
S - 316L Stainless Steel					S			
H - Hastelloy <sup>®</sup> C-276								
M - Monel <sup>®</sup> 400								
Z - Duplex 2205								
<b>Instrument Connection Size</b>								
04T - ½ NPT Female						04T		
<b>Options (if choosing option(s) must include an "X")</b>								
<b>Fill Fluid</b>							X_ _	
CF - Halocarbon <sup>®</sup>								
CC - Syltherm <sup>®</sup> XLT (for low-temperature applications)								
CG - Glycerin (direct-mount only)							CG	
CK - 50 cSt Silicone								
DJ - 10 cSt Silicone								
HA - Syltherm <sup>®</sup> 800 (for high-temperature applications)								
<b>Optional Features</b>								
DU - Instrument welded to seal								
PU - Pipe plug for flushing connection (511 only)								
NH - Stainless steel tag wired to product								NH
HY - Hydrostatic testing								
6B - Cleaning for oxidizing agents								
HP - High pressure design (510: 10,000 psi MAWP, 511: 5000 MAWP)								

# 510/511 All Welded Diaphragm Seal

## DIMENSIONS

For reference only, consult Ashcroft for specific dimensional drawings

510 Diaphragm Seal

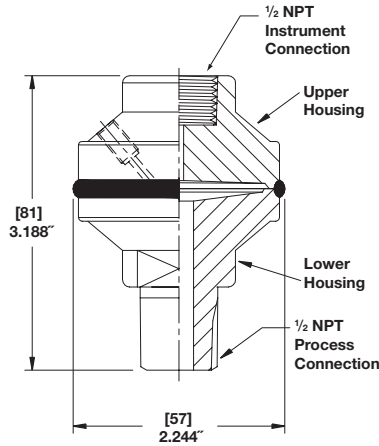

510 High Pressure Diaphragm Seal

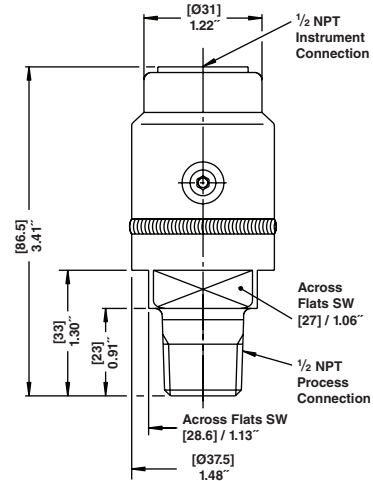

511 Diaphragm Seal with Flushing Connection

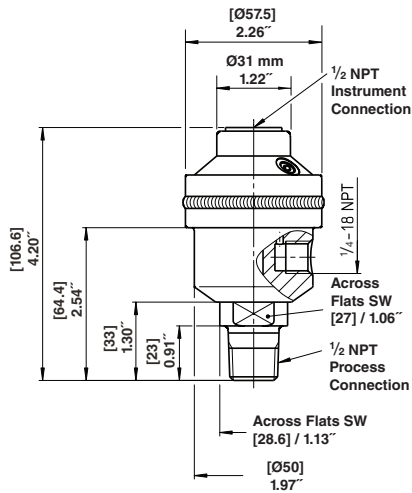

511 High Pressure Diaphragm Seal with Flushing Connection

